

Use recommendations

SLM40

CODIPROLUX SA
25, Salzbaach L-9559 Wiltz
Tel : +352 26 81 54 1 • Fax : +352 81 05 17
www.codipro.net • info@codipro.net

PRODUCT DESCRIPTION

These instructions apply to SLM40 lifting device manufactured by Codipro. The mold lifting system is composed of a subset base intended to be place on the crane hook and a subset slide screwed on the load. Three configurations exist see below schematics. The subset base exists in standard and heightened version (inside opening 300 and 400mm, respectively). The working load limit is 40t SF4.

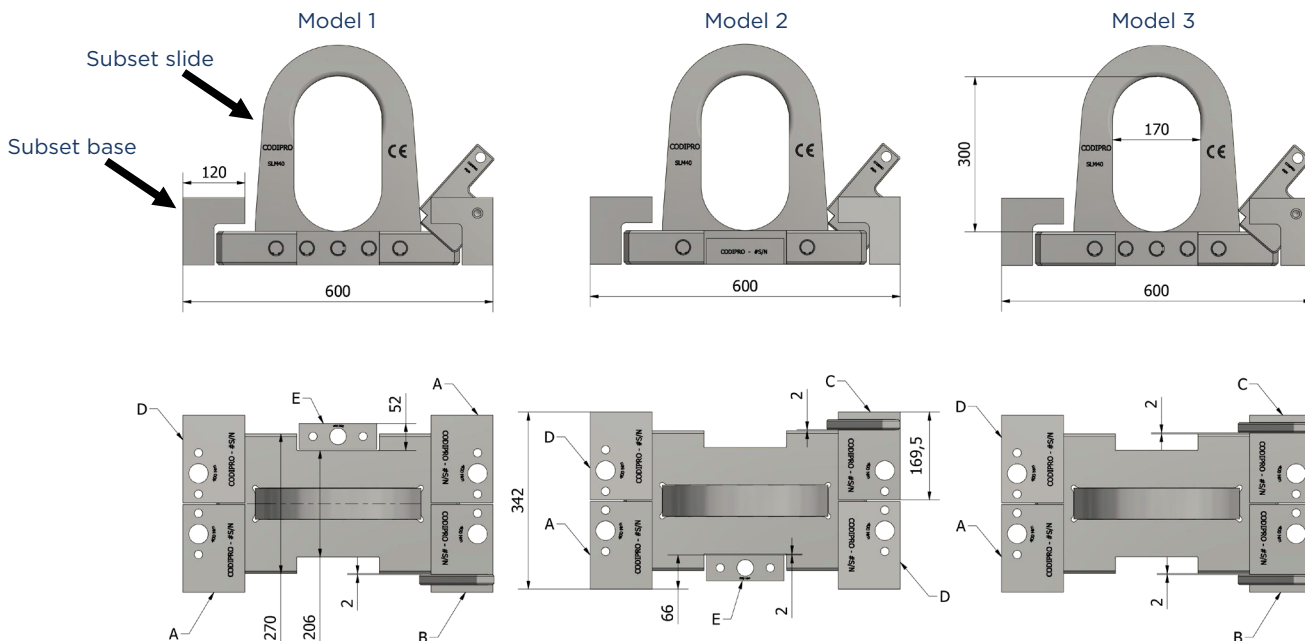
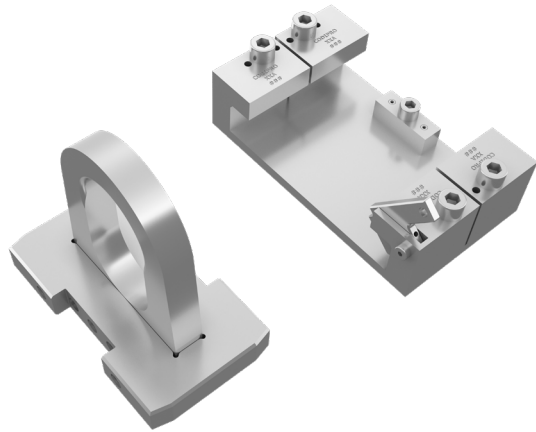

CERTIFICATION - QUALITY

Comply with directive on machinery 2006/42/EC. Delivery with EC declaration of conformity. Comply with Codipro specification. Static test coefficient: WLL x 2.5. Safety coefficient: 4. Certification only valid for equipment produced by Codipro and compliant with Codipro specifications. Any modifications performed without written permission of Codipro make the certification null and void.

CONDITIONS OF USE

General requirements

Only handled by capable and trained people following to current standards in force on the place of use. Prohibited to pass under a suspended load and/or to expose staff in the handling area. During handling, avoid any dangerous operations: shocks, tugs, vibrations. Scrupulously follow the WLL engraved on the accessory. All connected elements with the accessory must be in proportion to it and in accordance with standards in force.

Proceed to the adequacy verification of the accessory in relation to its use:

- Check that the head loss of the accessory assembly plus the load ensures safe lifting.
- Use the lifting points on the load that are located above the center of gravity to avoid it tilting.
- Check the correct displacement of the accessory/load/fastening point assembly to avoid any deterioration.
- Identify the path followed by the load clear the aisles and area to place the load.
- Never stand between the load and an obstacle or a wall.

Avoid using in corrosive, aggressive and/or sandy, chemical, acidic or steamy areas. Equipment designed for use at a temperature between -20°C and +100°C. Do not use outside this temperature range. Base subset designed for maximum 100 000 cycles with a 10% overload coefficient. Get in contact with the manufacturer for any specific use and/or additional information.

Special conditions

The threaded holes allowing to fix the lifting system to the load must be in accordance with European standards in force and long

SLM40 Use recommendations - Original version
In accordance with « directive on machinery » 2006/42/CE

02.2020

enough to fit with the full bolt length. Equipment designed for straight lift only. Do not use when vertical angle exceeds 5°. Rotating operations are forbidden. The operator has to make sure the locking system is closed before any lifting operation.

ASSEMBLY

General requirements

Consider the center of gravity and place the system right above to allow a 0° straight lift. All accessories must remain fully mobile in all directions without hindrance to movement. Please refer to the manufacturer use recommendations.

Special conditions

Please follow the assembly instructions:

1. Check each part visually prior to assembly and make sure there is no defect.
2. Put the parts together according to the installation drawings
3. Screw the bolt on with the dedicated tightening torque
4. Please refer to general operating instructions for lifting

Type	Quantity model 1	Quantity model 2	Quantity model 3	Tightening torque
Bolt M30x100mm	1	1	0	250 Nm
Bolt M36x180mm	4	4	4	400 Nm
Cotter pin ø16x100mm	10	10	8	-

Subset Slide Installation

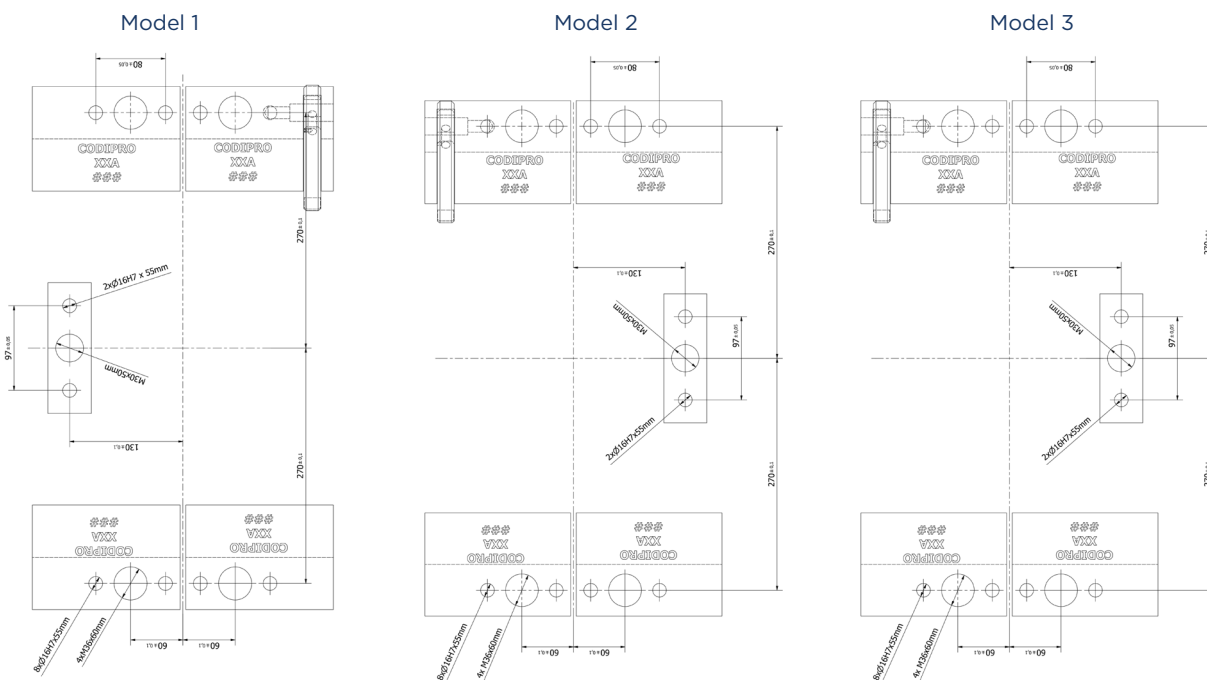

OPERATING INSTRUCTIONS

1. Get a working area correctly prepared for lifting. Please refer to equipment's manual for use.
2. Put the accessory together with the crane hook
3. Get close to the load and put the accessory into the lifting point. Check assembly of the load and accessory, as well as the locking mechanism and the safety systems.
4. Put the lifting set in tension and start lifting slowly. Pay close attention to the motion of the whole assembly.
5. Watch out for collisions during lifting.
6. Drop off the load slowly in a suitable area.
7. Take the lifting accessories off.

CONTROL AND MAINTENANCE

Control should always be carried out by capable and trained people in accordance with standards currently in force on the place of use. A visual control prior to each use is necessary. The following points must always be checked:

- Wear, bending, abnormal corrosion
- Assembly and articulation of movable parts
- Bolt tightening torques
- Nicks, deformation, cracks
- EC mark and engraving (WLL, traceability, manufacturer)

Subset base	
	Base
First assembly	Visual control
Each use (visual)	Wear Deformation
Annual control (visual + dimensionnal)	Wear Deformation Cycle usage Service booklet

SLM40 Use recommendations - Original version
In accordance with « directive on machinery » 2006/42/CE

02.2020

If one of these criteria is considered non-conform, the material must be subject to a more thorough examination.

	Subset slide		
	Bracket	Latch	Stop
First assembly	M36 bolts Tightening torque Visual control	Free operation	M30 bolts Tightening torque Visual control
Each use (visual)	Wear Deformation M36 bolts Tightening Visual control	Wear Deformation M36 bolts Tightening Visual control Free operation	Wear Deformation M30 bolts Tightening Visual control
Annual control (visual + dimensionnal)	Wear Deformation M36 bolts Tightening torque Visual control Service booklet Screws and bolts replacement where required	Wear Deformation M36 bolts Tightening torque Visual control Free operation Service booklet Screws and bolts replacement where required	Wear Deformation M30 bolts Tightening torque Visual control Service booklet Screws and bolts replacement where required

A thorough verification must be performed once a year for normal use, several times a year in case of intensive use. It is recommended to replace the bolts and pins after a 10 000 lifting cycle usage.

STORAGE

Store the system on a dedicated support. Regularly clean the accessory (use cloth and water only). Lightly grease to avoid corrosion in case of long-term storage.